

BALTOSPOT CERAM35



High voltage range:	100 to 300kV
Tube current range:	0,5 to 5 mA
Beam angle:	40°
Inherent Filtration (mm):	1 Be
Anode cooling type:	Air
Duty cycle:	100%
Insulation:	SF6 gas
Mains:	180 - 260V
Temp. switch:	70°C
Weight (without rings):	29 kg
Tubehead:	Ceramic
Control Unit:	CF2000 or Hand-X

MAIN FEATURES

- Pulsed wave technology
- Ceramic tube insert
- Air cooled
- Unique energy recovery module
- Rugged and light control unit
- Safety first, x-ray start with 2 buttons
- Full automatic preheating
- Works on power generator
- Very stable output
- Low consumption



Ceramic tubehead

KEY ADVANTAGES

- Very reliable
- Ergonomic guard rings
- Temperature pressure switch
- Full automatic preheating process
- Low power requirement
- Cables with reduced size and weight
- Can be delivered with our 900g Hand-X including a Geiger-Müller detector
- CANON mil. metallic connectors
- Steadiness & Sturdiness

MOST COMMON APPLICATIONS

- Oil & Gas
- Shipyard building & Building sites
- Petrochemical & Power plants
- Foundries
- Railway parts
- Boiler or pressure vessels manufacturers



Balteau NDT is known for its unique and unequalled engineering and manufacture of portable equipment. The CERAM 35 is the result of the latest evolution of electronic and physics of X-rays. It has been engineered to meet and exceed your needs for now and the future.

The CERAM 35 is delivering 300 kV and 5 mA with a duty cycle of 100% for an incredible image contrast even at full power. Thanks to a purposely designed tubehead and driving electronics, the CERAM 35 is offering to the user both duty cycle and an enormous power to fit any important requirements.



MECHANICAL DRAWING

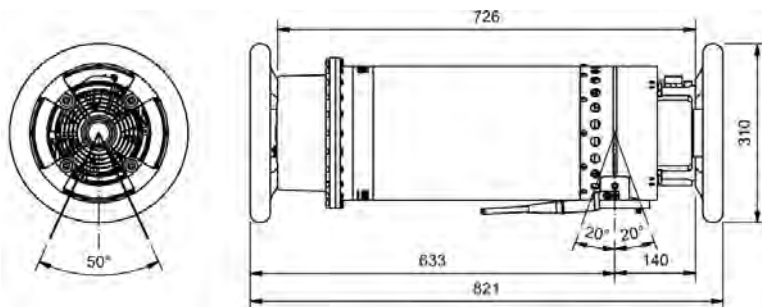

Gas insulation and right components selection have succeeded in producing one of the lightest 300kV in the market. The unit is extremely versatile and is confirming our reputation of builders for machines that are really made for field inspection.

INTERNATIONAL

- CE certified
- NFC74-100 LCIE Certified
- Manufactured under ISO9001

Specifications	Units	CERAM35
High voltage range:	kV	100 - 300
Tube current range:	mA	0,5 - 5
Maximum anode power dissipation:	Watt	1500
Beam angle:		40°
Focal spot size (IEC336):	mm	2,5 x 2,5
Steel penetration at max (*):	mm	58
Max recommended temp.:	°C	50°
Temperature switch:	°C	70°
Inherent filtration:	mm (Be)	1
Anode cooling type:		Air
Duty cycle:	%	100
Mains:	V	180 - 260
Weight (without rings):	Kg	29
Tubehead:		Ceramic
Control unit:		CF2000 or Hand-X

* FFD= 700mm/Film Carestream Industrex AA400/D=2.0/t=10min.



CF2000

- kV min step: **1**
- mA min step: **0,1**
- Time min step: **1 sec up to 99min 59sec**
- Memories: **100 last exposure/memories**
- Display: **4 lines, green back lighting**
- Mains: **170-260 V**
- Weight: **12,5kg**

STANDARD EQUIPMENT

- Internal pressure gauge
- Heavy duty lock type connector
- 20m connecting cable for control unit
- 10m power cable
- Cradle with heavy duty hand rings
- Holder for centering device filter & diaphragm
- Bag for accessories



Hand-X (Wireless remote control)

- kV min step: **1**
- mA min step: **0,1**
- Time min step: **1 sec up to 99min 59sec**
- Memories: **100 last exposure/memories**
- Display: **4 lines, green back lighting**
- Battery: **8h charge capacity**
- Weight: **900g**

OPTIONAL EQUIPMENT

- Lead shutter
- AVARA/P
- Warning flashing light & repeater
- Transport case
- Cradle & 4 legs adjustable stand
- Hydraulic stand
- 100-260 V adapter



Russell Fraser Sales Pty Ltd

Unit 7/38 Waratah St
Kirrawee NSW 2232

Ph: (02) 9545 4433
Fax: (02) 9545 4218

Email: rfs@rfsales.com.au
Web: www.rfsales.com.au

ABN: 79 074 258 549